



# ACCOR

HELENE

SELF - SERVICE INTEGRAL COUNTERS



### Benefits & Specifications:

- Unique and stylish design
- High product visibility
- Harmonia Helene; mobile plug-in counter on castors.
- Sloped base deck to display products even if the counter is placed against the wall.
- User-friendly
- Small footprint with compact design
- Easy access and ergonomic design
- Easily adaptable to seasonal needs
- Low operating costs
- Simplified maintenance
- Wide range of future refrigerant options

### Dimensions (mm):

Height : 1034  
Length : 1215  
Depth : 1076

SYSTEM	OPERATING TEMP. °C	REFRIGERANT
PLUG-IN	+2 / +4	HC HFC blend HFC / HFO blend

HC: R290 / R1270 • HFC: R407A / R407F / R134A / R404A • HFC / HFO: R448A / R449A / R452A / R450A

## TECHNICAL DATA

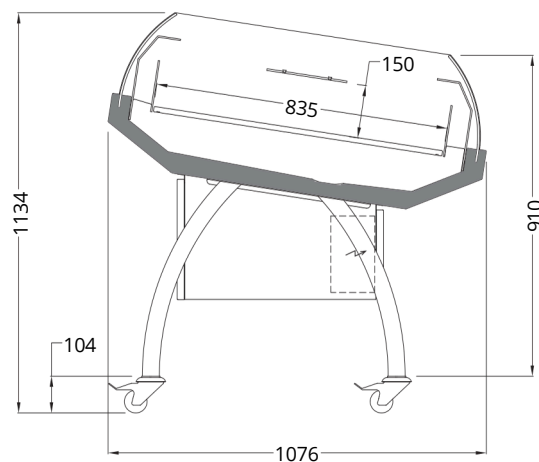

ACCOR HELENE

Length mm | 1215

# WHERE QUALITY MEETS RELIABILITY

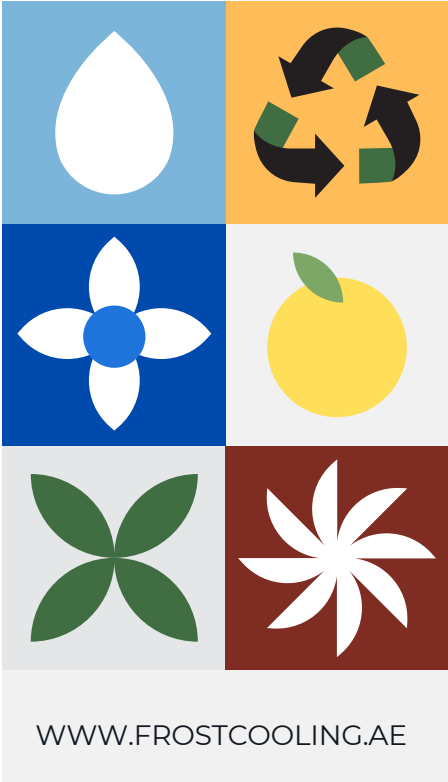

FROST COOLING TRADING  
SALES: +971 58 553 8232  
OFFICE: +971 58 520 5232  
EMAIL: SALES@FROSTCOOLING.AE