



FROST 900

SERVE OVER INTEGRAL COUNTER

CG FISH





FROST 900

SERVE OVER INTEGRAL COUNTER

CG FISH



Benefits & Specifications:

- User-friendly
- Small footprint with compact design
- Easy access and ergonomic design
- Customized solutions for individual needs
- Fully configurable to different concepts
- Easily adaptable to seasonal needs
- Low operating costs
- Simplified maintenance
- Wide range of future/ refrigerant options

Dimensions (mm):

Height : 1145

Length : 1250 / 1875 / 2500 / External Corner 90°

Depth : 1180

SYSTEM	OPERATING TEMP. °C	REFRIGERANT
PLUG-IN	-1 / +1	HC HFC blend HFC / HFO blend

HC: R290 / R1270 • HFC: R407A / R407F / R134a / R404A • HFC / HFO: R448A / R449A / R452A / R450A



TECHNICAL DATA

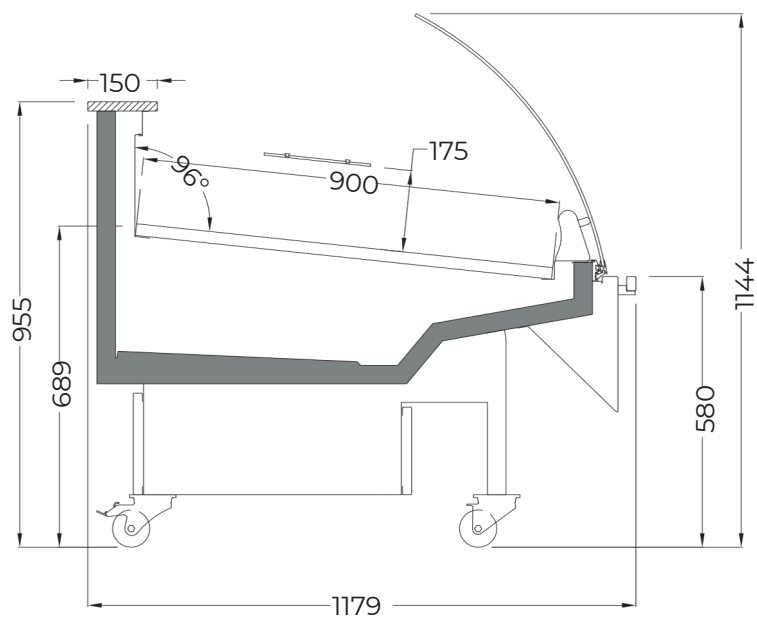

FROST 900 CG FISH

Length mm | 1250 | 1875 | 2500 | EC 90

WHERE QUALITY MEETS RELIABILITY

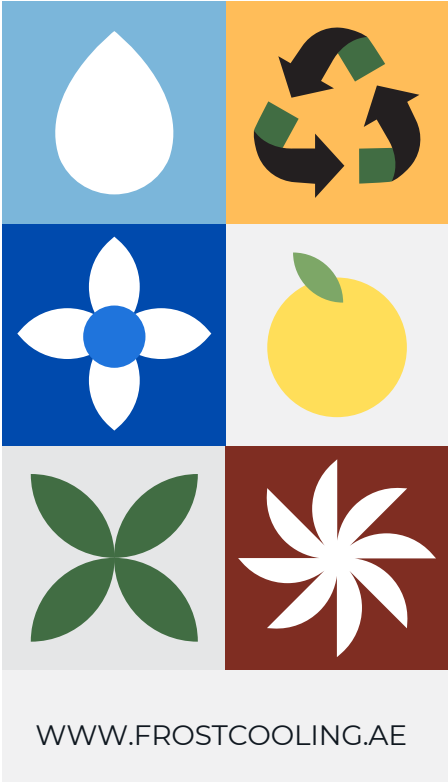

FROST COOLING TRADING
SALES: +971 58 553 8232
OFFICE: +971 58 520 5232
EMAIL: SALES@FROSTCOOLING.AE