

Nominal ton*			7.5
Model			FROST COOLING 7.5
Cooling	Capacity	Btu/h	89,000
		kW	26.0
	Input	kW	7.9
	EER	Btu/h.W	113
Heating	Capacity	Btu/h	103,000
		kW	30.0
	Input	kW	8.9
	COP	Btu/h.W	11.6
Airflow	Indoor side	CFM	2,830
External static pressure		Pa	Default: 80:0-250
Max. power input		kW	12
Max. current		A	248
Compressor	Type / Quantity		Scroll/1
	Brand		Danfoss
Indoor fan	Type / Drive type		Centrifugal/Direct
Outdoorfan	Type / Drive type		Axial/Direct
Wired controller			KJR-25B
Centralized controller (Optional)			Yes
Sound pressure level		dB(A)	72.1
Ambient temperature	Coolhg		10° C-46° C
	Heating		-9° C-24° C
Dimension	Net(WxHxD)	mm	1,475X840X1,130
	Packing (WXHXD)	mm	1,495X870X1,150
Weight	Net/Gross	kg	244/249

Notes:

- Cooling capacity test condition (1): Outdoor ambient temperature: 35° C, indoor temperature 26.7\* CDB/19.4° C WB; Heating capacity test condition (2): Outdoor ambient temperature: 7 CDB/6° C WB, indoor temperature 20^ C DB/ 15° C WB;
- Units are suitable for operation to ± 20% of nominal CFM;
- Sound values are measured in a semi-anechoic room, at a position 1 meter in front of the unit and (1 meter+Height of unit)/2 above the floor.
- Specifications are subject to change without prior notice for product improvement.
- \* Nominal ton only for reference.
- Cooling or heating capacity as per specifications.

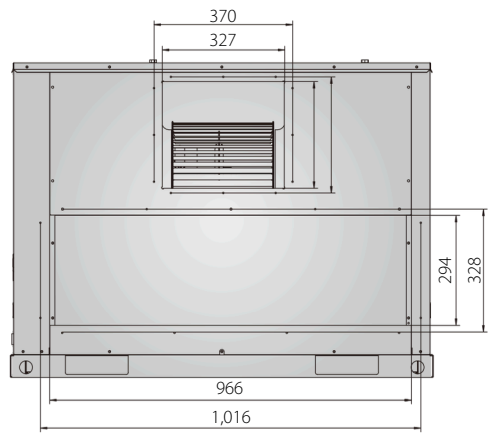
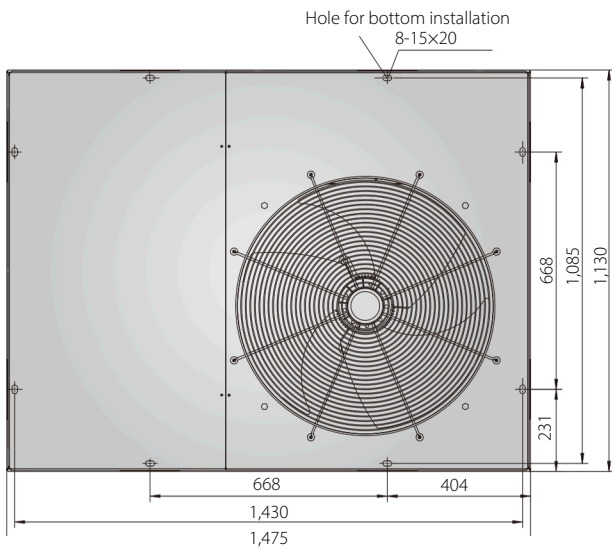
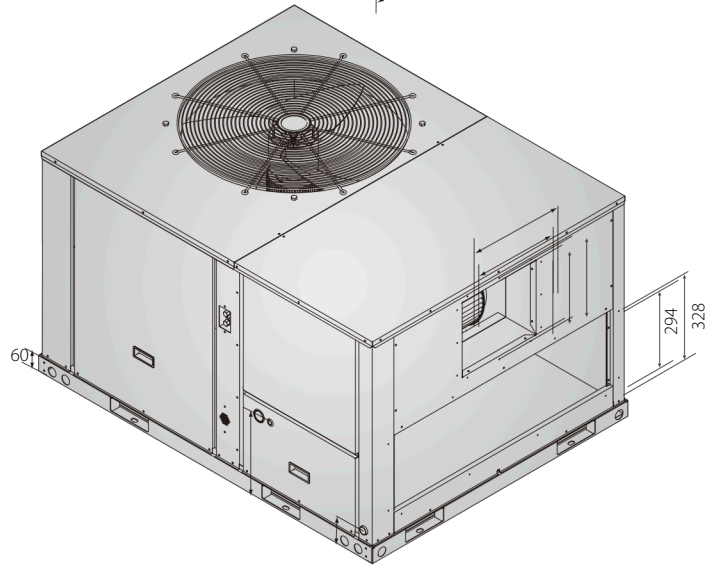
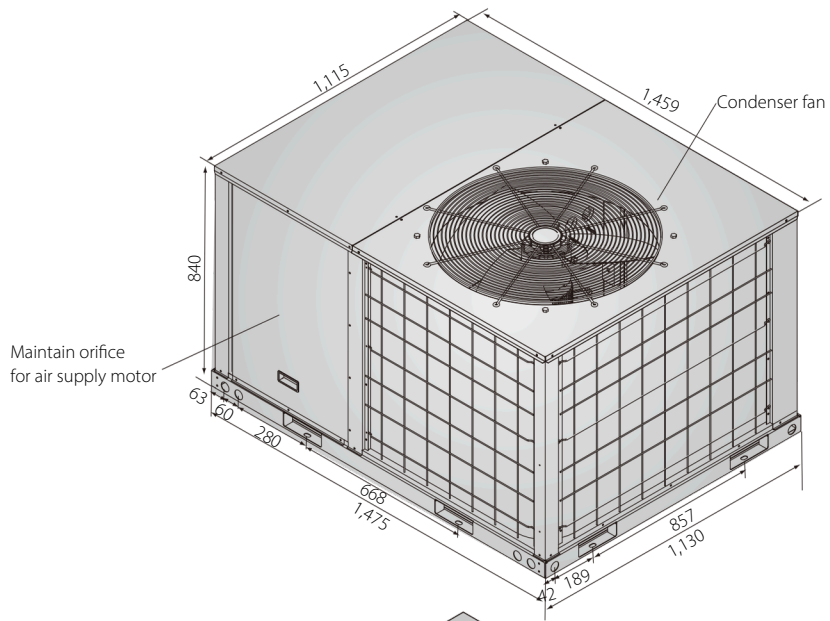

## Design flexibility

- ❖ Compact design.
- ❖ Flanges of air flow inlet and outlet as standard.
- ❖ It is suitable for installation on rooftop and ground.



## OUTSTANDING RELIABILITY

### Durable construction

- ❖ Pre-painted exterior cabinet panels pass 500 hours Salt Spray Test for durability.
- ❖ Weather-resistant construction with capped steams and sloped top panels.
- ❖ G90 galvanized heavy gauge plate conforming to ASTM-A-653.



### Customized anti-corrosion treatment

- ❖ The rooftop package air conditioners with special anti-corrosion treatment are suitable for seaside areas or the areas exposed to acidic substances.



- ❖ Special anti-corrosion treatment of heat exchanger provides 5 to 6 times greater resistance against acid rain and salt corrosion.
- ❖ All PCB parts in the unit are coated with double-side moisture proof paint. The outer side of electric box metal cover is spray-painted.
- ❖ All screws are anti-rust.
- ❖ Casings of the unit and motors are anti-rust.

## Reliable scroll compressor

- ❖ Famous brand compressor: Copeland, Hitachi, Danfoss, etc.. More reliable.
- ❖ No complex internal suction and discharge valves for quieter operation and higher reliability.
- ❖ Compact, light-weight, and fewer moving parts design.

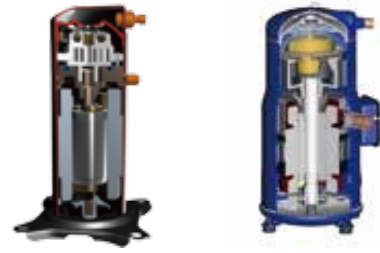

## Multi-protection design

- ❖ Multiply measures to ensure units operate normally and reliably:  
System current protection, High/low pressure protection, Temperature sensor protection, etc.
- ❖ Three-phase protector can be customized.



HP/LP switch



Temperature sensor

# EASY TO INSTALLATION

## Convenient for wires connection

- ❖ Removable access door on the electric box. It is easy to move the cover of the electric box.
- ❖ Only connect the wires of power supply, and no need to connect any signal wires.



## Easily connect the drainage pipe

- ❖ Reserved external drainage port, quickly and accurately connect the rubber drainage pipe.



# EASY TO MAINTENANCE

## External pressure gauge ports



- ❖ The unit provides external pressure gauge ports for convenient and fast checking system pressure without removing the panel.

## Easy access doors design

- ❖ Removable the access doors on the filter, fan motor, and electric box sections.
- ❖ Provide convenient access to system components for maintenance and service.

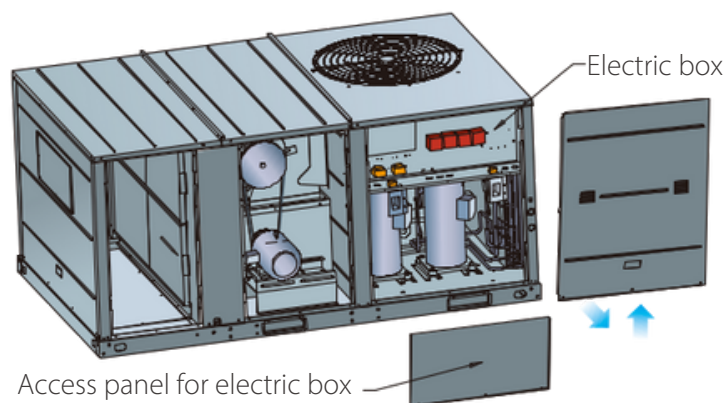

## System self-diagnostic

- ❖ Press the 'Check' button, the LED display in PCB board of the unit will display the normal checking code.
- ❖ If the unit is in running with abnormal operation, the LED display will show the error code.



## Washable filter

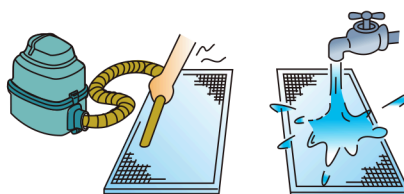

**FROST COOLING TRADING LLC**

Location: European Business Center, 3rd Floor, Office No. BC-26, DIP 1, Dubai, U.A.E

Telephone: +971-585205232 Email: sales@frostcooling.ae