

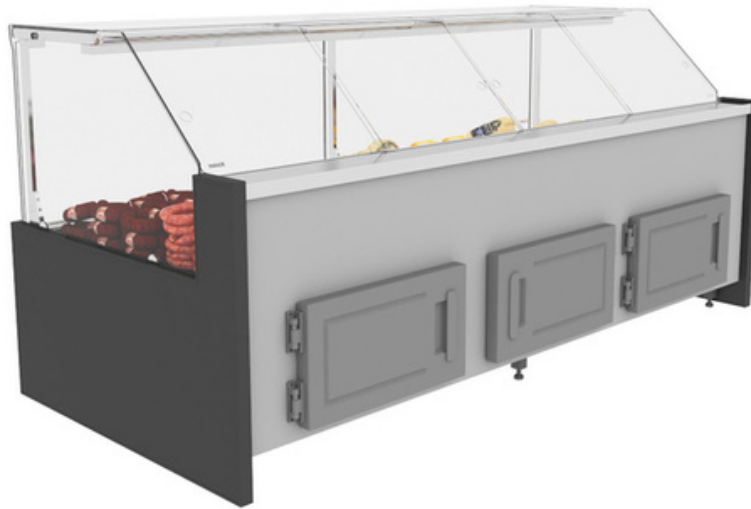

FROST STORAGE

SERVE - OVER COUNTER with INTEGRATED STORAGE





Benefits & Specifications:

- Flushed or tiered shelving for easy service
- Easily adaptable to seasonal needs
- Small footprint with increased display area
- Ideal for a wide variety of food & beverage presentations

Dimensions (mm):

Height : 1200 (SQ) / 1225 (CG)
 Length : 1250 / 1875 / 2500 / 3750
 Depth : 1150

SYSTEM	OPERATING TEMP. °C	REFRIGERANT
REMOTE	-1 / +1 +2 / +4	HFC blend HFC/HFO blend CO ₂ Glycol / Water

HFC: R407A / R407F / R134a / R404A • HFC/HFO: R448A / R449A / R452A / R450A
 CO₂: R744 • GLYCOL/WATER: R718

TECHNICAL DATA

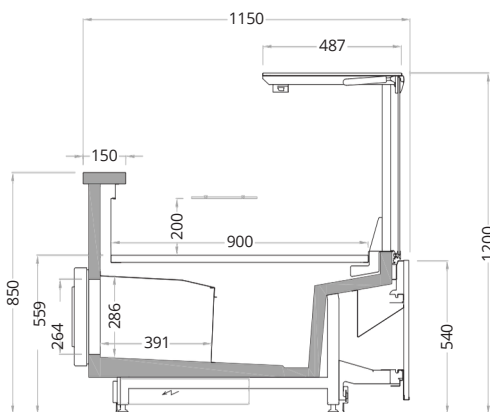

FROST 900 / 1200 / 1150 / 549 - SQ - AA - DP

Length mm | 1250 | 1875 | 2500 | 3750

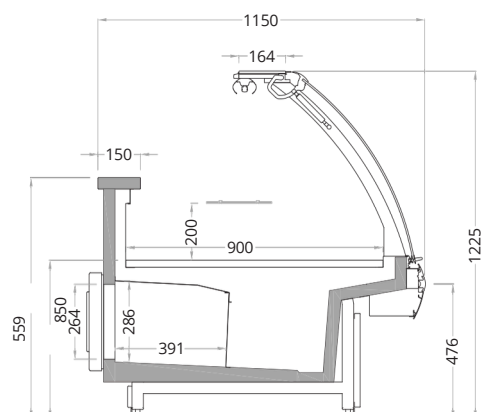

FROST 900 / 1225 / 1150 / 476 - CG - DP

Length mm | 1250 | 1875 | 2500 | 3750

WHERE QUALITY MEETS RELIABILITY

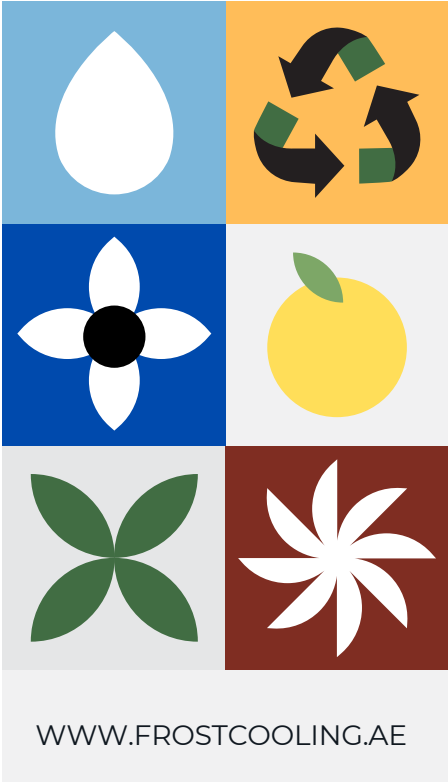

FROST COOLING TRADING
SALES: +971 58 553 8232
OFFICE: +971 58 520 5232
EMAIL: SALES@FROSTCOOLING.AE