



IRIS

SEMI VERTICAL MULTI-DECK



IRIS

SEMI VERTICAL MULTI-DECK



Benefits & Specifications:

- Small footprint with compact design
- Easy access and ergonomic design
- Fully configurable to different concepts
- Ideal for wide variety of food presentations
- Designed for modular configurations
- Simplified maintenance
- Low operating costs
- Delivers high standard of performance

Dimensions (mm):

Height : 1500

Length :

Run Cabinets : 1250 / 1875 / 2500 / 3750

End Cabinets : 1660 / 2136

Depth : 850 / 1000 / 1100

SYSTEM	OPERATING TEMP. °C	REFRIGERANT
REMOTE	-1 / +1 +2 / +4 +4 / +6	HFC blend HFC/HFO blend CO ₂

HFC: R407A / R407F / R134a / R404A • HFC/HFO: R448A / R449A / R452A / R450A
CO₂: R744

TECHNICAL DATA

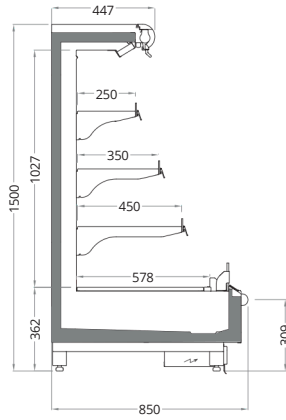

IRIS V3 850 HI500
 Length mm | 1250 | 1875 | 2500 | 3750 | HC:1660

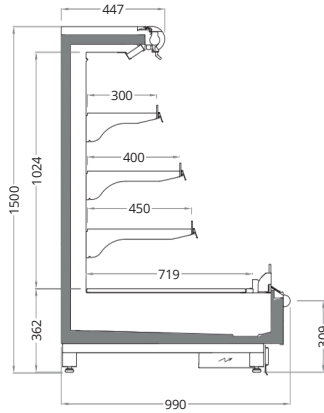

IRIS V3 1000 HI500
 Length mm | 1250 | 1875 | 2500 | 3750 | HC:2136

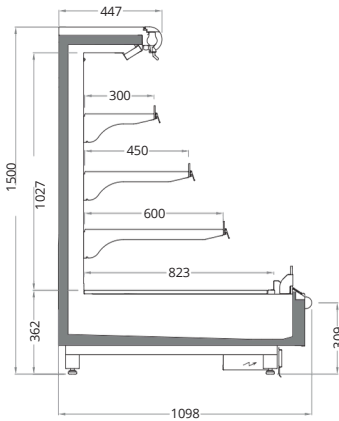

IRIS V3 1100 HI500
 Length mm | 1250 | 1875 | 2500 | 3750 | HC:2136

CURVED GLASS DOORS

FLAT GLASS DOORS

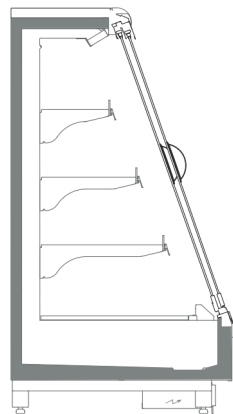
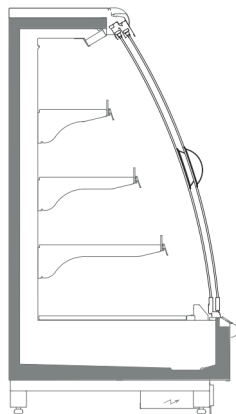

ACCESSORIES



PLEXI SHELF RISER



WIRE SHELF RISER



SHELF LIGHTING

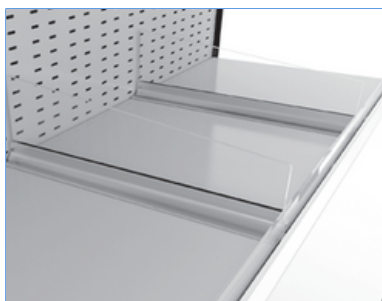

PLEXI PRODUCT DIVIDER

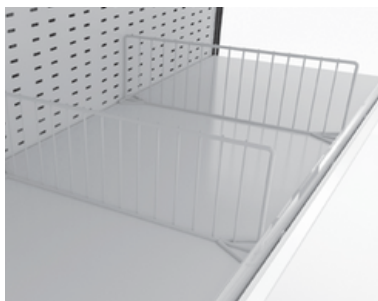

WIRE PRODUCT DIVIDER

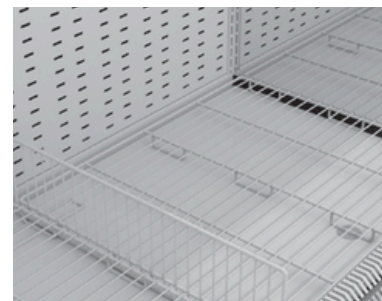

WIRE BASE TRAY
WIRE BASE PRODUCT DIVIDER

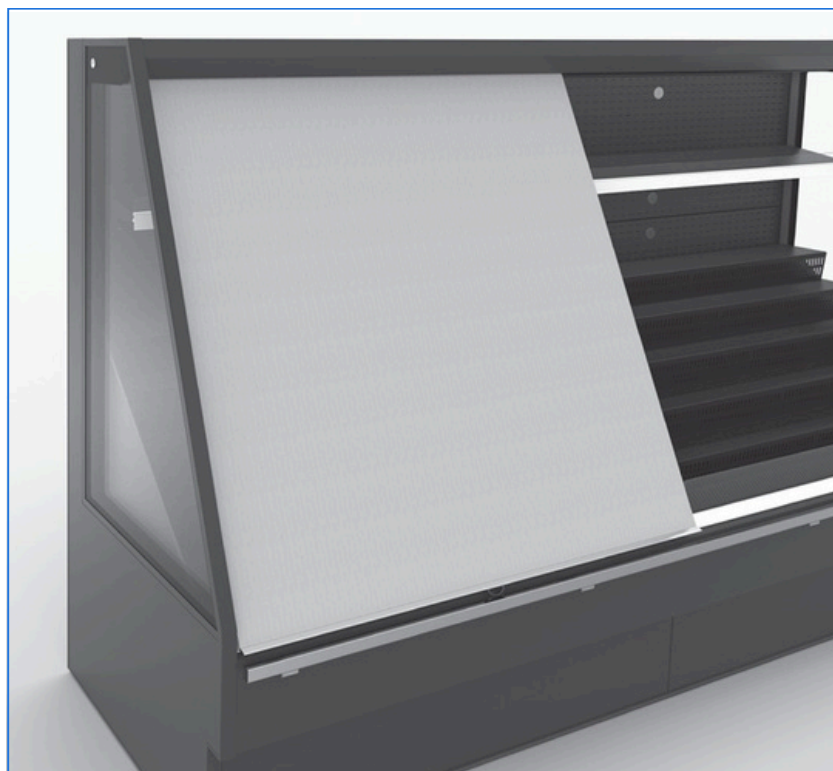

NIGHT BLIND

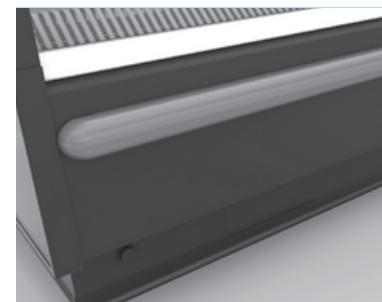

PLASTIC BUMPRAIL

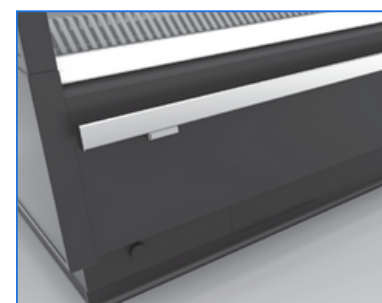

STAINLESS STEEL BUMPRAIL

TECHNICAL DATA

ISLAND CONFIGURATION

- ① HEAD CASE
- ② RUN CASE

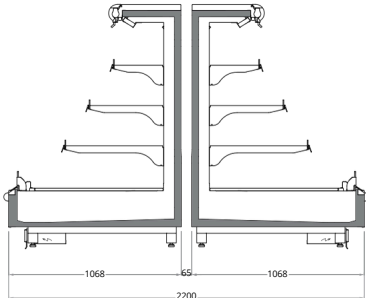
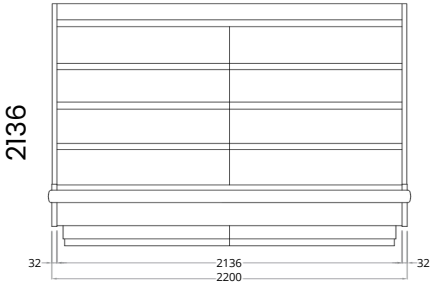
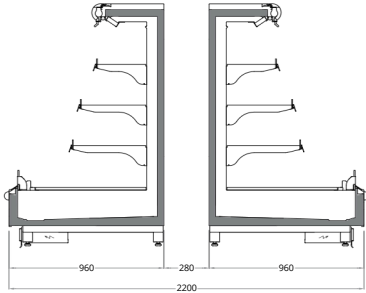
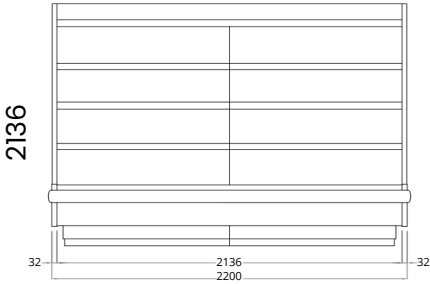
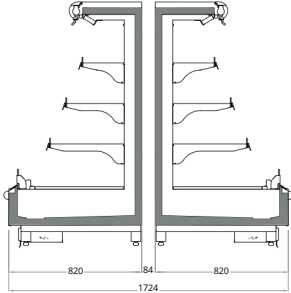
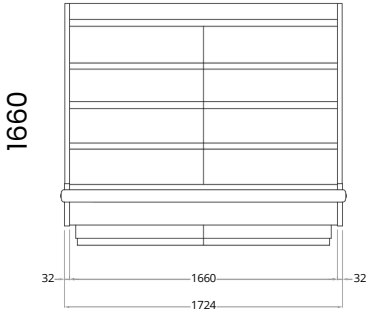
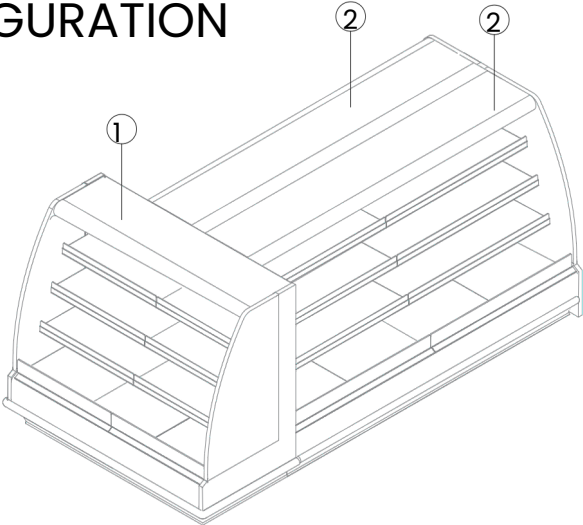

WHERE QUALITY MEETS RELIABILITY

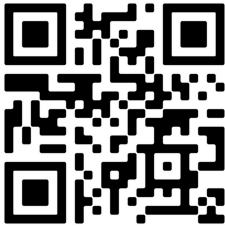
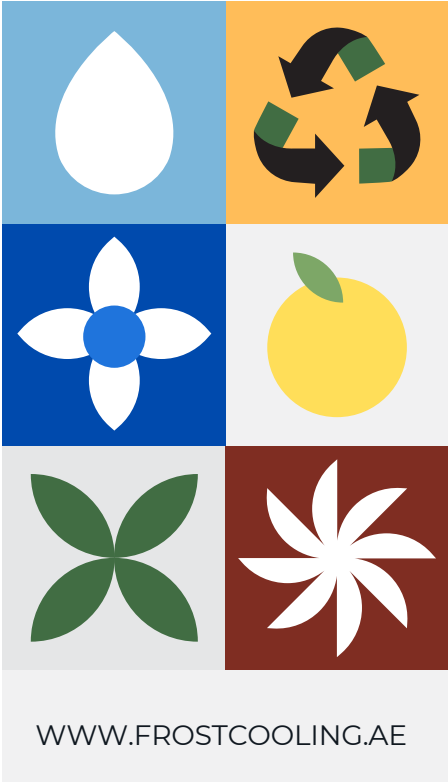

FROST COOLING TRADING
SALES: +971 58 553 8232
OFFICE: +971 58 520 5232
EMAIL: SALES@FROSTCOOLING.AE