



# NIVO FROST TOWER

SELF - SERVICE INTEGRAL COUNTERS



### Benefits & Specifications:

- Shelves are nonrefrigerated
- Commendable eye-catching display
- Multi- features to easy service operations
- Handy product replenishment through multi opening features
- Accessible and ergonomic
- Increased display area
- Dynamic lighting
- Fully configurable through different height options to different concepts

### Dimensions (mm):

Height : 1554  
Length : 1250 / 2500  
Depth : 1150

SYSTEM	OPERATING TEMP. °C	REFRIGERANT
REMOTE	+2 / +4	HFC blend HFC/HFO blend CO <sub>2</sub> Glycol / Water

HFC: R407A / R407F / R134a / R404A • HFC/HFO: R448A / R449A / R452A / R450A  
CO<sub>2</sub>: R744 • GLYCOL/WATER: R718

## TECHNICAL DATA

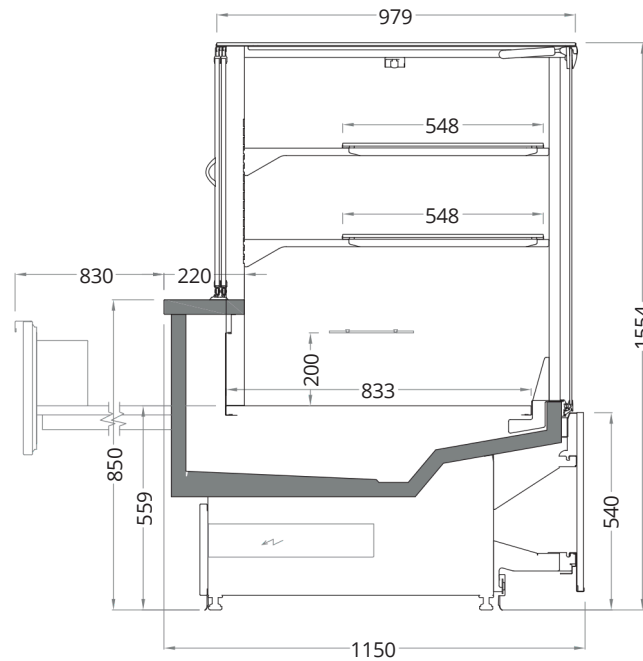

NIVO TOWER 830 / 1554 / 1150 / 540 - SQ - AA

Length mm | 1250 | 2500

# WHERE QUALITY MEETS RELIABILITY

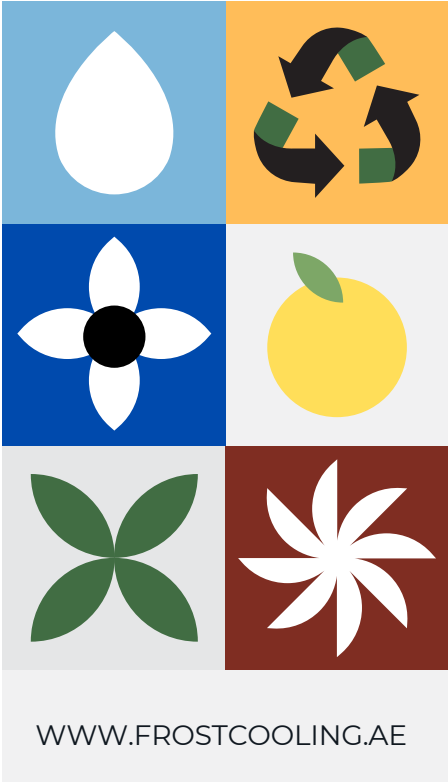

**FROST COOLING TRADING**  
SALES: +971 58 553 8232  
OFFICE: +971 58 520 5232  
EMAIL: SALES@FROSTCOOLING.AE