



ISLA

WELL ONLY CHILLED INTEGRAL CABINET
WELL ONLY FROZEN INTEGRAL CABINET
WELL ONLY BI-TEMP INTEGRAL CABINET





ISLA

WELL ONLY CHILLED INTEGRAL CABINET
WELL ONLY FROZEN INTEGRAL CABINET
WELL ONLY BI-TEMP INTEGRAL CABINET

Eye-catching design for multi-temperature purposes. Elegant, ergonomic, high visibility and environmentally friendly. You can switch operational temperature as you wish depending on seasonal purposes; chilled or frozen.



Benefits & Specifications:

- User-friendly
- Small footprint with compact design
- Easy access and ergonomic design
- Customized solutions for individual needs
- Fully configurable to different concepts
- Easily adaptable to seasonal needs
- Low operating costs
- Simplified maintenance
- Wide range of future refrigerant options



Dimensions (mm):

Height : 941 / 1000 (with Castors)
 Length : 1000 / 1500
 Depth : 1040

TECHNICAL DATA

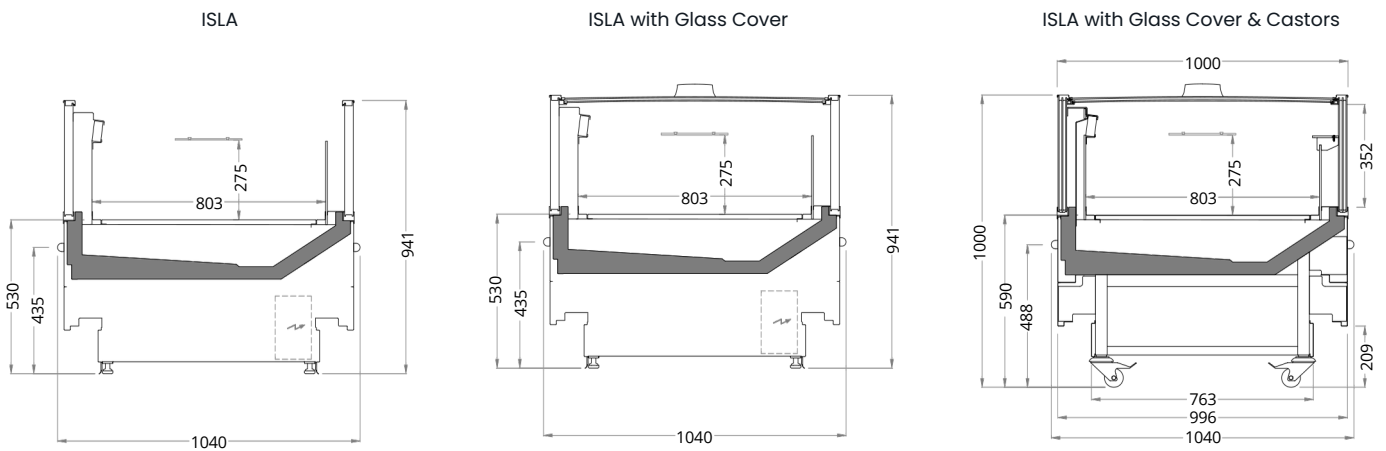

SYSTEM	OPERATING TEMP. °C	REFRIGERANT
PLUG-IN POSITIVE	-1 / +1 +2 / +4	HC HFC blend HFC / HFO blend
PLUG-IN NEGATIVE	-22 / -24 -20 / -22	
PLUG-IN BI-TEMP	CHILLED -1/+1 +2/+4 FROZEN -22/-24 -20/-22	

ISLA
 Length mm | 1000 | 1500

HC: R290 / R1270 • HFC: R407A / R407F / R404A • HFC / HFO: R448A / R449A / R452A

WHERE QUALITY MEETS RELIABILITY

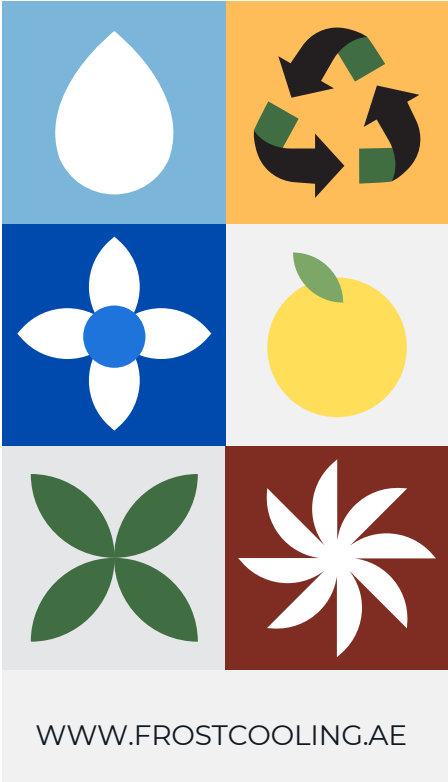

FROST COOLING TRADING
SALES: +971 58 553 8232
OFFICE: +971 58 520 5232
EMAIL: SALES@FROSTCOOLING.AE