



# SCENIC

WELL ONLY SELF-SERVICE INTEGRAL CABINET





# SCENIC

WELL ONLY SELF-SERVICE INTEGRAL CABINET

Transparency, lightness and efficiency are the distinguishing features of Scenic which is designed to combine advanced display solutions and high loading capacity.



### Benefits & Specifications:

- User-friendly
- Small footprint with compact design
- Easy access and ergonomic design
- Customized solutions for individual needs
- Fully configurable to different concepts
- Easily adaptable to seasonal needs
- Low operating costs
- Simplified maintenance
- Wide range of future/ refrigerant options



### Dimensions (mm):

Height : 1014  
 Length : 1360  
 Depth : 1009

SYSTEM	OPERATING TEMP. °C	REFRIGERANT
PLUG-IN	+2 / +4	HC HFC blend HFC / HFO blend

HC: R290 / R1270 • HFC: R407A / R407F / R134a / R404A • HFC / HFO: R448A / R449A / R452A / R450A

## TECHNICAL DATA

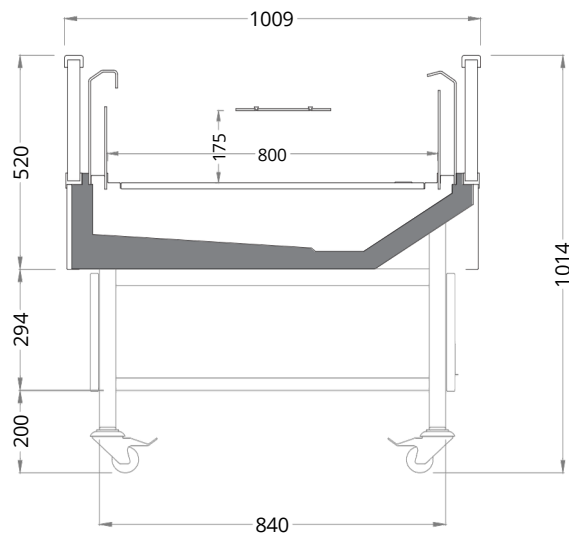

**SCENIC**

Length mm | 1360 (with endwalls)

# WHERE QUALITY MEETS RELIABILITY

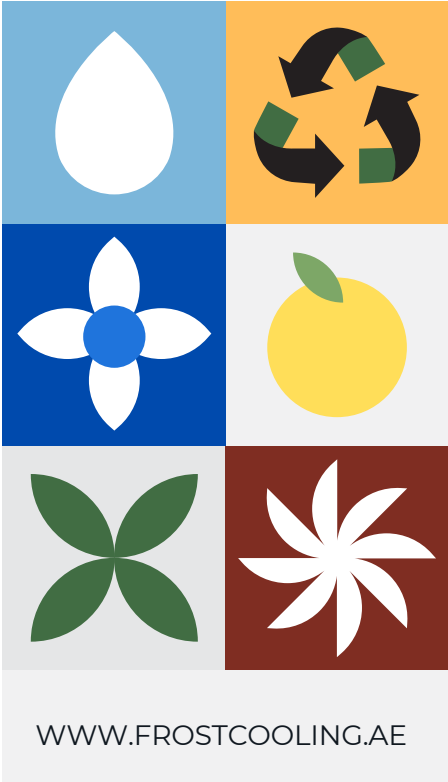

**FROST COOLING TRADING**  
SALES: +971 58 553 8232  
OFFICE: +971 58 520 5232  
EMAIL: SALES@FROSTCOOLING.AE